

# Designing *Your Stand*

Guidelines for creating the  
perfect space for you brand.

**in** life  
**in** style.

**in** kids  
**in** style.

17-20 FEBRUARY 2024  
ICC SYDNEY

# What do I get as a *standard package*?

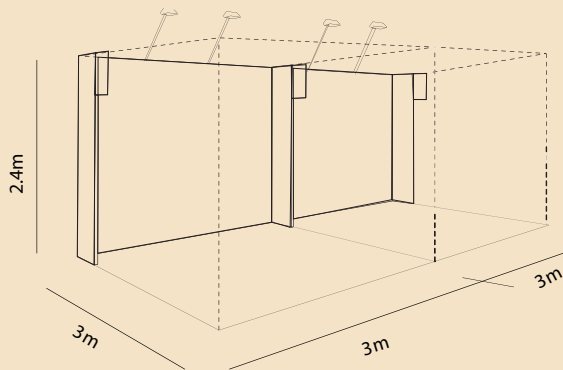

The *basic package* includes the following:

- White art panel back wall (2.4m high x 40mm thick x 1m linear panels)
- 50cm wide support return on each side
- 1 x 300 watt arm light per 1.5m (additional lights can be ordered)
- 1 X A3 sign affixed to the side returns on each end of your stand (includes company name and stand number)
- NO SIDE WALLS
- Please note the depth of your stand will be either 2m, 2.5m, or 3m. If you are unsure of the depth of your stand please contact your account manager

## Support Nibs

Stands longer than 3m will require a 50cm wide support nib for every 3m of walling to help reinforce the wall. In some cases this can be removed dependent on the stand configuration within your block. A nib notification email will be sent to all exhibitors notifying them of the location of nibs within their stand once the build plans for the event have been finalised. Support nibs cannot be removed unless approved and signed by the official contractor only.

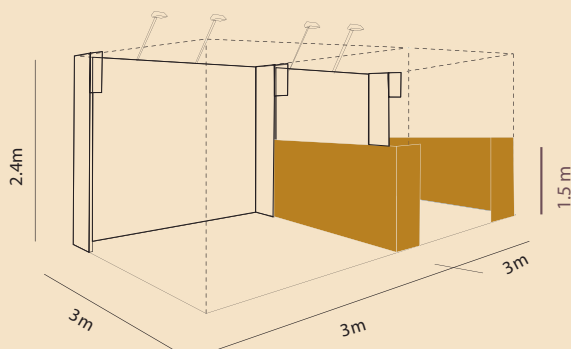

## What about *side walls*?

SIDE WALLS ARE NOT INCLUDED BUT CAN BE ORDERED AS AN OPTIONAL EXTRA

- Side walls are 1.5m in height and 16mm thick
- A 50cm wide support nib will sit at the end of the wall to keep it from falling down
- When neighbours order the same wall you will each be refunded 50% of the cost (post event)
- You CANNOT use a side wall (ie attach to, lean on, decorate) unless you have ordered it through the Expoconnect portal in Form 5
- You will be charged post event if you do so
- YOU ARE NOT PERMITTED TO BUILD YOUR OWN SIDE WALLS

## Which side is which?

When ordering side walls imagine yourself standing inside your stand with your back against the back wall, facing out to determine which side is left or right.

## Is there anything else *I need to order*?

### WILL YOU BE REQUIRING MORE POWER?

If you wish to plug in any electrical items such as lighting, a laptop, phone charger etc, you will need to order power. There are 2 options;  
 4AMP – suitable for one item only  
 10AMP – suitable for 2-3 items at the same time. Power and extra lighting can be ordered through the Expoconnect portal in Task 8.

## Do you want *more light*?

In addition to the venue's own ceiling lights, all stands (excluding space only) are inclusive of 1x300w arm light per 1.5m. The number of lights is dependent on stand size as shown in the table. If you feel you will require more you can order extra.

STAND LENGTH	LIGHTS
3 - 4 m	2 lights
5 m	3 lights
6 - 7 m	4 lights
8 m	5 lights
9 - 10 m	6 lights
11 m	7 lights
12 m	8 lights

Arm lights cannot be attached to side walls.

# Height Restrictions

## THE RULES IN BLACK & WHITE

When designing the layout of your stand and purchasing props, display units etc you will need to keep in mind the strict height restrictions designed to maximize visibility for buyers across the exhibition floor.

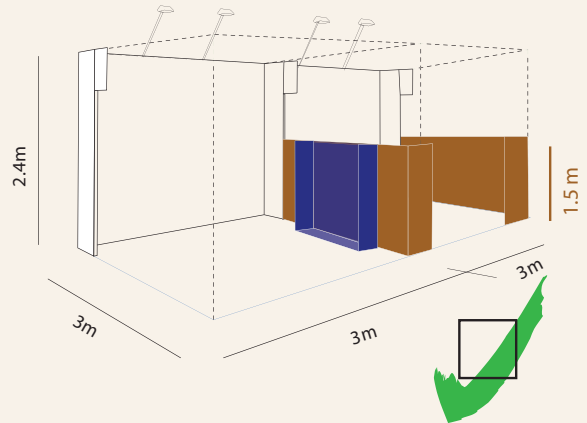
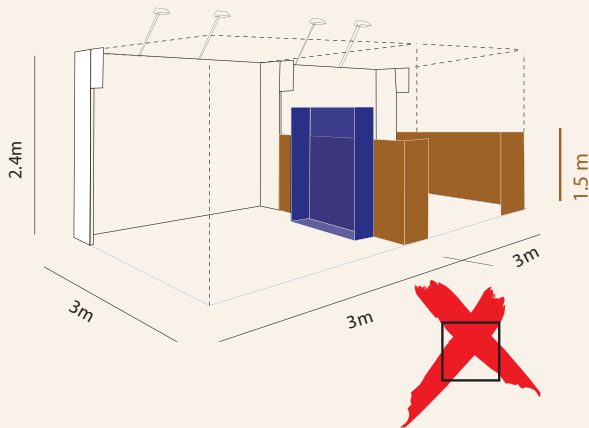

### On the sides

Items within your stand which sit on the side of the stand must be below 1.5m in height, so as not to close off the view to your neighbouring stand.

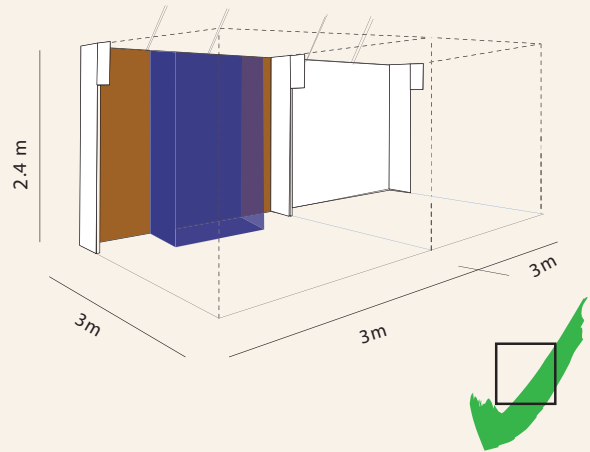
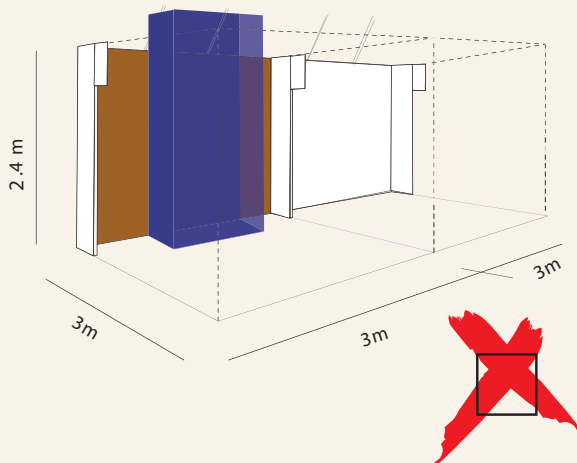

### Against the back walls

Items within your stand which sit on the back of the stand must be below 2.4m in height, so as they are not visible to the stands behind you. Exceptions can be made for stands without exhibitors behind them.

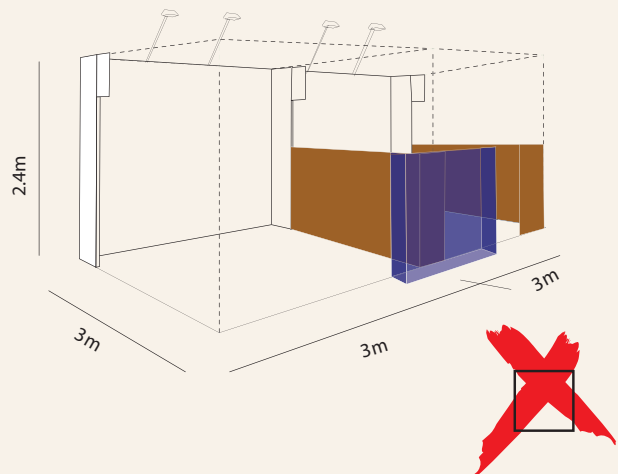
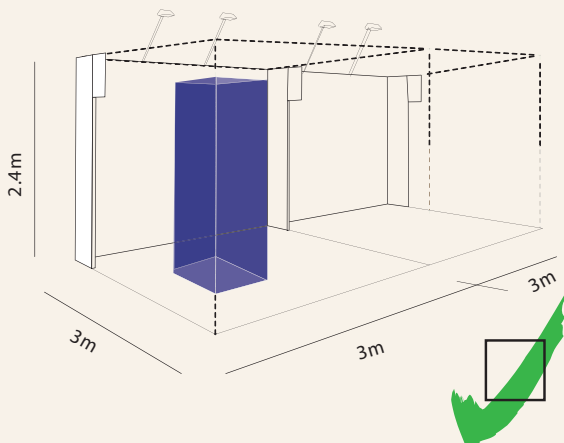

### What about in the middle?

Items within your stand which sit in the centre of the stand can be up to 2.4m in height as long as they do not completely block off the view to your neighbour.

### Aisles?

Items must stay within the designated space of your stand, they cannot sit in or encroach the aisles.

# Stand Design:

## CAN AND CAN'T DO'S

**TIP:** To hold items best, screw directly into the horizontal struts shown in the diagram on the right.

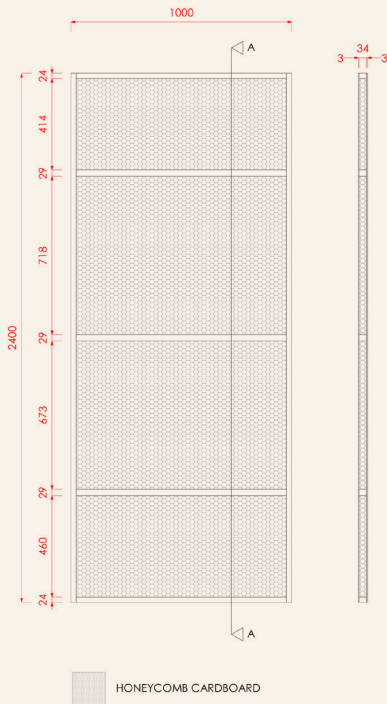

## Nailing & Screwing Into Walls

You are welcome to nail or screw into any of your stand walls keeping the following in mind:

- Your back wall is 40mm thick and side walls only 16mm thick. Please make sure your nails or screws do not poke through the other side.
- There is a weight restriction of 20kg per panel for attaching items to the back walls. Side walls can hold a total weight of 10kg.

## Painting & Wallpapering Walls

Your walls can be painted or wallpapered, however please keep in mind;

- You CANNOT paint your own walls onsite. Painting must be pre-booked through the Expoconnect portal in Task 8 at an additional cost per linear metre (excl. paint cost)
- You CANNOT use wallpaper glue as this will ruin the walls. Please tack with pins, nails, screws or use double sided tape.

**TIP:** When working out designs for your back wall keep in mind that 40mm will be lost off the width of your back wall due to the support ribs (20mm at each end). So for a 3m wide stand, the area to be covered will actually be 2.96m wide x 2.4m tall.

If your stand is 3m or wider, you MAY have a support nib for every 3m of walling to help re-inforce the wall. Please check with your Account Manager.

If your stand is a corner stand, for a 3m stand the width of your back wall will be 2.94m to account for the nib between them and their neighbour (20mm) and the nib on the end (40mm).

**TIP:** As a cost effective alternative to having the walls pre-painted, why not pre-paint or wallpaper your own thin MDF or ply panels at home and then attach these to the wall itself. Please note you must remove the wallpaper after the show closes.





## Flooring

If you wish to put flooring or carpet over the existing flooring please keep the following in mind:

- You CANNOT paint, nail, screw or glue to any floor, ceiling or wall within the venue
- Flooring must be secured to ensure no exhibitors or guests are exposed to the possibility of injury or slipping
- Tape must be removed carefully from the floor after the event finishes

Flooring is 'industrial concrete'. All rules stated above will apply.

## Signage

Your stand includes 1 X A3 sign affixed to the side returns on each end of your stand (includes company name and stand number), however we suggest creating your own signage /branding either on your walls or within your stand build.

**TIP:** See our list of suppliers in the Exhibitor Manual for who offers signage solutions

## Rigging

Rigging and suspension of banners, lighting and objects directly above your stand is available depending on the location of your stand.

- There is a weight restriction of 20kg per rigging wire.
- Requests for rigging availability and quotes can be made via the Exhibitor Manual.



# Space Only & Custom Build Stands

As an alternative to a complete stand package some stands are available to purchase as “space only” (ie; no walls or lighting) with the intention of employing a contractor to build a custom self supporting stand. You can still employ a stand builder (or even build it yourself ) to bring your design to life even with a standard package, working with or in front of the existing walls. Your stand includes 1 X A3 sign affixed to the side returns on each end of your stand (includes company name and stand number), however we suggest creating your own signage /branding either on your walls or within your stand build.

**TIP:** Full service custom stand design and construction is available through the stand builder of your choice or we can recommend Exponet. See our suppliers list on the exhibitor manual for contact details

**NOTE:** All designs for custom build stands MUST be submitted to the operations team for approval 6 weeks prior to onsite via Task 7.

If you are employing the services of any external contractors or suppliers you must register their details via Task 11.

## Need more help?

If this document didn't answer all your questions, please feel free to get in touch with our team.

We love when our exhibitors think outside the box creatively so if you have an idea you feel may break our guidelines, put it forward & our team will happily review it!

**DANIELLE BENNETT**  
Strategic Account Manager  
02 9422 2769  
danielle.bennett@rxglobal.com

**JAYDE TAYLOR**  
Strategic Account Manager  
02 9422 8694  
jayde.taylor@rxglobal.com

**LILY NUTTING**  
Operations Manager  
02 9422 2390  
lily.nutting@rxglobal.com

**EMMA PETERSEN**  
Senior Operations Manager  
0417 564 312  
emma.petersen@rxglobal.com



Organised by RX Global Australia  
Tower 2, 475 Victoria Avenue, Chatswood NSW  
02 9422 8686 | info@lifeinstyle.com.au  
ABN 47 000 146 921

life  
in style.

